

**Alden-Pro LED Panel Installation**  
**Installation du panneau LED Alden-Pro**  
**Installazione del pannello LED Alden-Pro**

Products Covered:  
**ALD3627-SCT**  
**ALD1203-SCT**  
**ALD1206-SCT**

Please read these instructions thoroughly before use and retain for future reference.  
 Veuillez lire attentivement ces instructions avant utilisation et les conserver pour une utilisation future.  
 Si prega di leggere queste istruzioni attentamente e di conservarle per future necessita'



<p><b>GB</b>  <b>Safety Information</b></p> <ul style="list-style-type: none"> <li>Installation must be carried out in accordance with national building and wiring regulations. If you are in any doubt about installing this product, please consult a qualified electrician.</li> <li>Before commencing installation or any maintenance, turn off and isolate the circuit to be worked on by removing the fuse or switching the circuit breaker off at the distribution board.</li> <li>This product is suitable for connection to a 220-240Vac 50/60Hz supply.</li> <li>The drivers are a class II product not requiring an Earth connection though a terminal marked E is provided for Earth continuity and are IP20 rated for indoor use only.</li> <li>The panels are a class III product and are IP20 rated unless otherwise indicated (IP44 when ceiling recess mounted – <b>ALD1203-SCT, ALD1206-SCT</b>) (IP65 when ceiling recess mounted – <b>ALD3627-SCT</b>)</li> </ul>	<p><b>FR</b>  <b>Information sur la sécurité</b></p> <ul style="list-style-type: none"> <li>Avant de commencer l'installation ou tout manipulation, éteindre et isolez le circuit en retirant le fusible ou en coupant le disjoncteur au niveau du tableau de distribution</li> <li>L'installation doit être réalisée selon les règles de câblage et de constructions en vigueur. Si vous avez un doute sur l'installation de ce produit, veuillez consulter un électricien qualifié.</li> <li>Ce produit est conçu pour une alimentation 220-240V AC 50/60Hz.</li> <li>Les pilotes sont un produit de classe II ne nécessitant pas de connexion à la terre bien qu'une borne marquée E soit fournie pour la continuité de la terre et sont classés IP20 pour une utilisation en intérieur uniquement.</li> <li>Les panneaux sont un produit de classe III et sont classés IP20, sauf indication contraire (<b>ALD1203-SCT, ALD1206-SCT</b>) (IP65 en cas de montage encastré au plafond – <b>ALD3627-SCT</b>)</li> </ul>	<p><b>IT</b>  <b>Informazioni di sicurezza</b></p> <ul style="list-style-type: none"> <li>Prima di iniziare l'installazione o qualsiasi intervento di manutenzione, spegnere e isolare il circuito su cui intervenire rimuovendo il fusibile o disinserendo l'interruttore automatico sul quadro di distribuzione.</li> <li>L'installazione deve essere eseguita in conformità con le normative edilizie e di cablaggio nazionali. In caso di dubbi sull'installazione di questo prodotto, consultare un elettricista qualificato.</li> <li>Questo prodotto è adatto per il collegamento a un'alimentazione 220-240Vac 50/60Hz.</li> <li>I driver sono un prodotto di classe II che non richiede un collegamento a terra sebbene sia fornito un terminale contrassegnato con E per la continuità di terra e sono classificati IP20 solo per uso interno.</li> <li>I pannelli sono un prodotto di classe III e hanno un grado di protezione IP20 se non diversamente indicato (IP44 in caso di montaggio a incasso a soffitto) (IP65 in caso di montaggio a incasso a soffitto – <b>ALD1203-SCT, ALD1206-SCT</b>) (IP65 in caso di montaggio a incasso a soffitto – <b>ALD3627-SCT</b>)</li> </ul>
<p><b>Optional Gears and Accessories Information</b></p> <ul style="list-style-type: none"> <li>The LED panels are compatible with the optional emergency modules which can power the panels at a reduced output in the event of a power failure. Please refer to instructions included with the emergency modules for installation.</li> <li>Alternative drivers may be available for dimming the panels. Please refer to alternative driver instructions for additional wiring requirements.</li> <li>The LED panels also can be flush mounted or suspended. Please refer to instructions included with the accessories for installation. The installer should be aware that there are external drivers that need to be accommodated.</li> </ul>	<p><b>Informations sur les engrenages et accessoires en option</b></p> <ul style="list-style-type: none"> <li>Les panneaux LED sont compatibles avec les modules d'urgence optionnels qui peuvent alimenter les panneaux à puissance réduite en cas de coupure de courant. Veuillez vous référer aux instructions fournies avec les modules d'urgence pour l'installation.</li> <li>Des pilotes alternatifs peuvent être disponibles pour la gradation des panneaux. Veuillez vous référer aux instructions alternatives du pilote pour les exigences de câblage supplémentaires.</li> <li>Les panneaux LED peuvent également être encastrés ou suspendus. Veuillez vous référer aux instructions fournies avec les accessoires pour l'installation. L'installateur doit être conscient qu'il existe des pilotes externes qui doivent être pris en charge.</li> </ul>	<p><b>Informazioni su ingranaggi e accessori opzionali</b></p> <ul style="list-style-type: none"> <li>I pannelli LED sono compatibili con i moduli di emergenza opzionali che possono alimentare i pannelli con potenza ridotta in caso di mancanza di alimentazione. Fare riferimento alle istruzioni incluse con i moduli di emergenza per l'installazione.</li> <li>Potrebbero essere disponibili driver alternativi per dimmerare i pannelli. Fare riferimento alle istruzioni del driver alternativo per ulteriori requisiti di cablaggio.</li> <li>I pannelli LED possono anche essere montati a filo o sospesi. Fare riferimento alle istruzioni incluse con gli accessori per l'installazione. L'installatore dovrebbe essere consapevole che ci sono driver esterni che devono essere sistemati.</li> </ul>
<p><b>Light Source Information</b>  <b>ALD3627-SCT, ALD1203-SCT, ALD1206-SCT</b> contain a light source of energy class D.</p> <p>The light source is defined as the LED module and backplate of the product itself.</p> <p><b>Notes for disassembly and disposal at end of product life:</b>          At the end of product life, the product should be disconnected from the mains supply by a suitably qualified person and dismantled into its constituent parts prior to disposal. Only commonly available tools* such as screwdrivers, knives, soldering irons, spanners, pliers etc should be used and appropriate safety measures taken during their use. Parts such as LED strips, LED panels, electrical control gear, wiring, plastic diffusers, metal components such as back plates or heatsinks should all be separated from the product and disposed of via appropriate waste streams. Please consult your local authority for WEEE recycling and disposal options.          *List of commonly available tools is not comprehensive, if in any doubt please contact Kosnic.</p>	<p><b>Informations sur la source lumineuse</b>  <b>ALD3627-SCT, ALD1203-SCT, ALD1206-SCT</b> contiennent une source lumineuse de classe énergétique D.</p> <p>La source lumineuse est définie comme le module LED et la plaque arrière du produit lui-même</p> <p><b>Remarques concernant le recyclage du produit:</b>          À la fin de la vie du produit, le produit doit être débranché de l'alimentation secteur par une personne qualifiée et démonté en ses éléments constitutifs avant d'être mis au rebut. Seuls les outils couramment disponibles* tels que tournevis, couteaux, fers à souder, clés, pinces, etc. doivent être utilisés et des mesures de sécurité appropriées doivent être prises lors de leur utilisation. Les pièces telles que les bandes LED, les dalles LED, les équipements de commande électrique, le câblage, les diffuseurs en plastique, les composants métalliques tels que les plaques arrière ou les dissipateurs thermiques doivent tous être séparés du produit et éliminés via les flux de déchets appropriés. Veuillez consulter votre autorité</p>	<p><b>Informazioni per la sorgente luminosa</b>  <b>ALD3627-SCT, ALD1203-SCT, ALD1206-SCT</b> contengono una sorgente luminosa di classe energetica D.</p> <p>La sorgente luminosa è definita come modulo LED e contropiastra del prodotto stesso.</p> <p><b>Note per lo smontaggio e lo smaltimento a fine vita del prodotto:</b>          Al termine della vita del prodotto, il prodotto deve essere scollegato dall'alimentazione di rete da una persona adeguatamente qualificata e smontato nelle sue parti costitutive prima dello smaltimento. Devono essere utilizzati solo strumenti comunemente disponibili* come cacciaviti, coltelli, saldatori, chiavi, pinze ecc. e devono essere prese le misure di sicurezza appropriate durante il loro utilizzo. Parti come strisce LED, pannelli LED, componentistica elettrica, cablaggio, diffusori in plastica, componenti metallici come piastre posteriori o dissipatori di calore devono essere tutti separati dal prodotto e smaltiti tramite idonei canali per la raccolta differenziata di rifiuti. Consultare l'autorità locale per le opzioni di riciclaggio e smaltimento.</p>

locale pour les options de recyclage et d'élimination des DEEE.  
 \*La liste des outils couramment disponibles n'est pas exhaustive, en cas de doute, veuillez contacter Kosnic.

\*L'elenco degli strumenti comunemente disponibili non è completo, in caso di dubbi contattare Kosnic

Installation Instruction / Instructions d'installation / Istruzioni di installazione

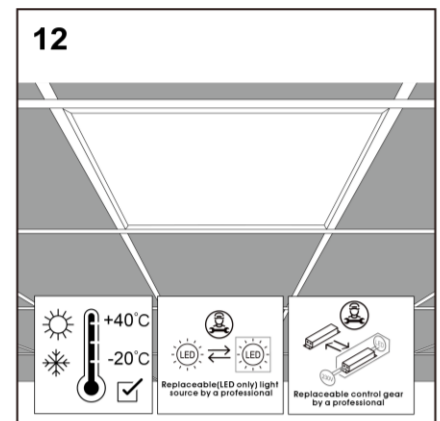
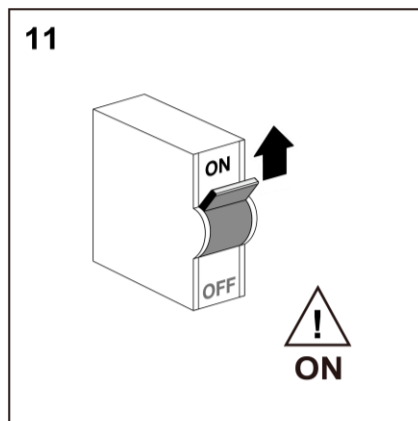
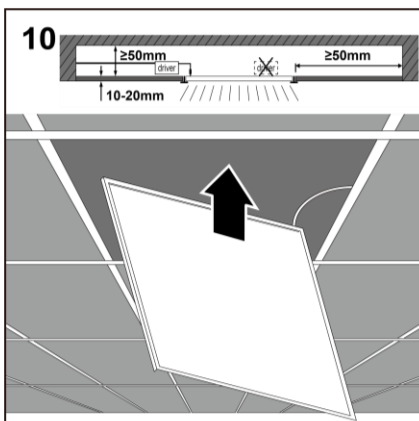
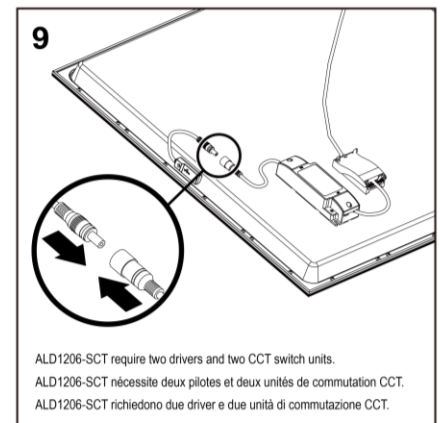
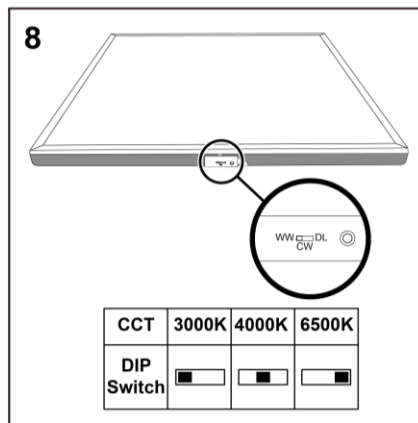
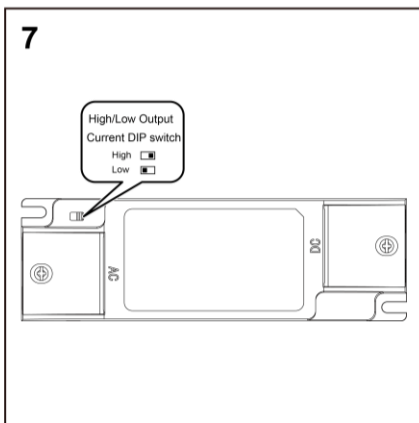
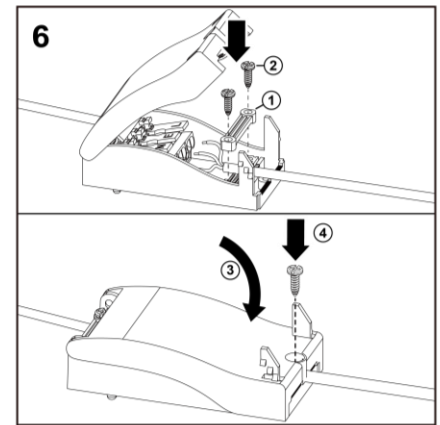
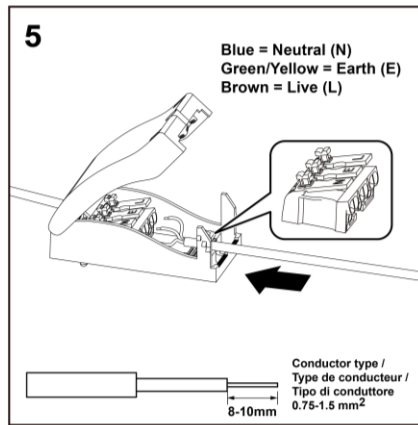
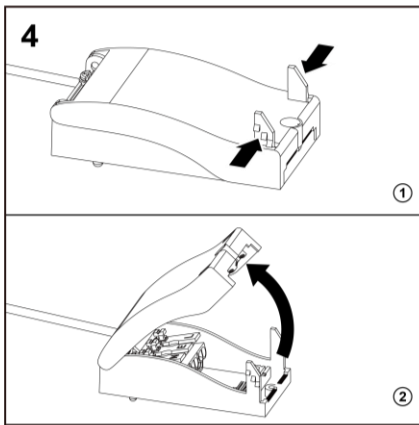
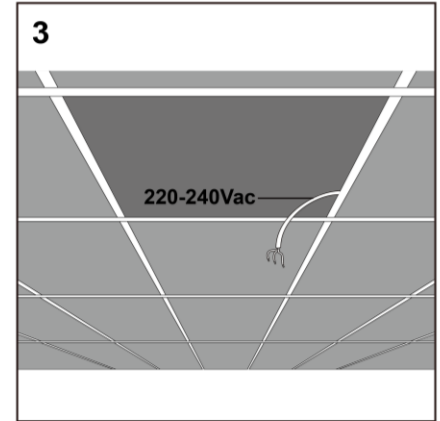
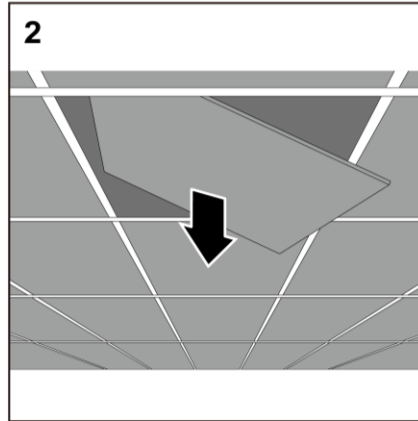
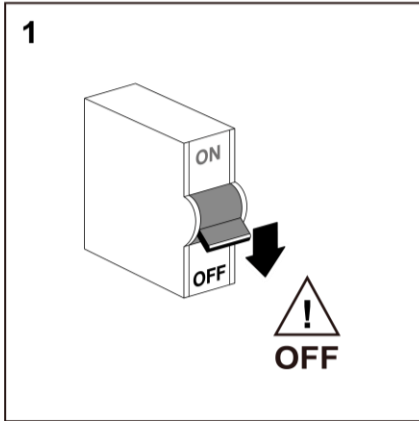

The Waste Electrical & Electronic Equipment Regulations (WEEE) require that products bearing this symbol must not be disposed of with household waste as they may contain substances harmful to the environment. The Local Authority can provide advice on recycling.